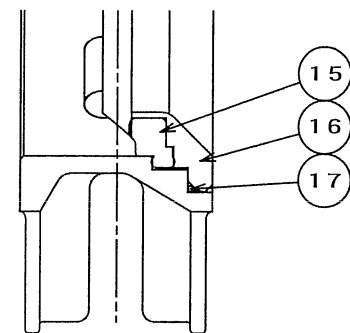

Table 1	Table 2
SCS13A	SUS304
SCS14A	SUS316

Table 3	Table 4
AROLAN II 6215+Si.R #1	NBR
V#8133+Si.R	CR
	EPDM
	PTFE

*1 STANDARD



RUBBER, TEFLON
SEAT

RUBBER SEAT : 0
TEFLON SEAT : 4cc/min X SIZE/25

注意

- "FLOW" は、液体およびガスの推奨流れ方向を示します。
- "N" は、片面の配管ボルト本数を示します。
- 図は、100A (4インチ) を示します。
- セットリングは、配管フランジにより必ずはさみ込んで下さい。配管時、セットリング側を下向けますと、セットリングが落下する恐れがあります。落下しないように注意して下さい。

ATTENTION

- "FLOW" shows the liquid and gas direction of the recommendation flow.
- "N" shows the plumbing bolt number of the one side.
- The figure shows 100A(4in).
- Set ring is fixed by the piping flanges. Set ring may, fall down while piping works, if it's side would turned to downward. Please pay your attention.

SIZE	d	d1	d2	L	g	f	f1	H	H1	W	MASS (About)
50A	70	48	65	48	89	17.4	1.6	293	349	200	6kg
65A	80	60	75	48	114	17.4	1.6	322	391	200	7kg
80A	96	72	93	51	125	18.4	1.6	334	416	200	9kg
100A	115	92	115	51	144	18.4	1.6	364	463	200	10kg
125A	140	116	140	57	172	21.6	1.6	450	564	280	17kg
150A	164	140	166	57	196	21.6	1.6	497	637	280	19kg

SIZE	JIS5K					JIS10K					ASME125Lb/150Lb					K
	D	C	n	N	h	D	C	n	N	h	D	C	n	N	h	
50A	157	105	2	4	M12	157	120	2	4	M16	157	120.7	2	4	5/8-11UNC	11
65A	177	130	2	4	M12	177	140	2	4	M16	177	139.7	2	4	5/8-11UNC	11
80A	185	145	2	4	M16	192	150	2	8	M16	185	152.4	2	4	5/8-11UNC	12.5
100A	223	165	2	8	M16	223	175	2	8	M16	223	190.5	2	8	5/8-11UNC	12.5
125A	256	200	2	8	M16	256	210	2	8	M20	256	215.9	2	8	3/4-10UNC	15
150A	282	230	2	8	M16	282	240	2	8	M20	282	241.3	2	8	3/4-10UNC	15

製番 MFG. NO.				
名称及形式 NAME AND TYPE		50A~150A		
		Type 336J-H KNIFE GATE VALVE		
番号 NO.	部品名称 PARTS NAME	材質 MATERIAL	数量 Q. ty	備考 REMARKS
1	BODY	See Table 1	1	
2	PLATE	See Table 2	1	
3	GLAND	See Table 1	1	
4	GLAND PACKING	See Table 3	1set	
5	STEM	SUS304	1	△
6	YOKE	SCS13	1	
7	SET PIN	SUS304	1	
8	BOLT, NUT, SW	SUS304	4	
9	BOLT, NUT, SW	SUS304	2	
10	YOKE SLEEVE	CAC406	1	
11	GREASE NIPPLE	C3601B	1	PLATED
12	HAND WHEEL	FCD450	1	
13	BOLT	SUS304	2	
14	STEM CAP	PLASTIC	1	
15	SEAT RING	See Table 4	1	
16	SET RING	SCS14	1	
17	PACKING	NON-ASBESTOS	1	
18	SCREW	SUS304	2	
19				
20				
21				
22				
23				
24				
25				

日付 DATE	OCT. 18, 2005	尺度 SCALE	FREE
使用圧力 WORKING PRESSURE	0~1.0 MPa Pe	使用温度 WORKING TEMP.	- °C
耐圧試験 SHELL TEST	1.1 MPa Pe	試験流体 TEST FLUID	WATER
弁座試験 SEAT TEST	0.28 MPa Pe	許容漏れ LEAKAGE	- %

作成 DRAWN	検討 CHECKED	承認 APPROVED
S.Y.		

OKM 株式会社 オーケーエム
OKUMURA ENGINEERING corp.

図面番号 DRAWING NO.	336J DA 1230 EC	FLOP. No.	
		Hd-lan975	

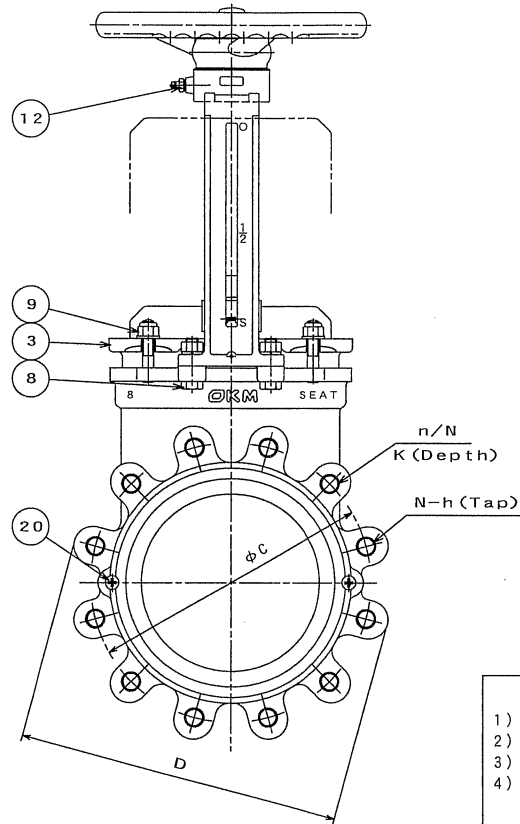
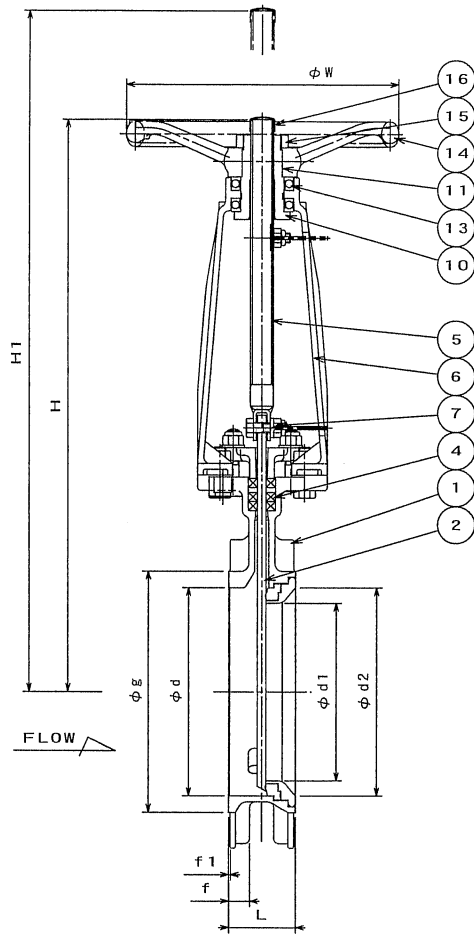
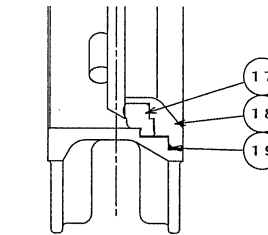

Table 3	Table 4
AROLAN II 6215+Si.R #1	NBR
V#8133+Si.R	CR
	EPDM
	PTFE

*1 STANDARD



RUBBER, TEFLON SEAT LEAKAGE

RUBBER SEAT : 0
TEFLON SEAT : 4cc/min × SIZE/25

注意

- "FLOW" は、液体およびガスの推奨流れ方向を示します。
- "N" は、片面の配管ボルト本数を示します。
- 図は、200A (8インチ) を示します。
- セットリングは、配管フランジにより必ずはさみ込んで下さい。配管時、セットリング側を下向けますと、セットリングが落下する恐れがあります。落下しないように注意して下さい。

ATTENTION

- "FLOW" shows the liquid and gas direction of the recommendation flow.
- "N" shows the plumbing bolt number of the one side.
- The figure shows 200A (8in).
- Set ring is fixed by the piping flanges. Set ring may, fall down while piping works, if it's side would turned to downward. Please pay your attention.

SIZE	d	d1	d2	L	g	f	f1	H	H1	W	MASS (About)
200A	216	184	216	70	250	22.4	1.6	591	790	280	31Kg
250A	266	232	270	70	308	26.9	1.6	701	938	355	51Kg
300A	317	274	306	76	360	28.1	1.6	815	1097	400	72Kg

SIZE	JIS5K					JIS10K					ASME125Lb/150Lb					K
	D	C	n	N	h	D	C	n	N	h	D	C	n	N	h	
200A	339	280	2	8	M20	335	290	4	12	M20	339	298.5	2	8	3/4-10UNC	19
250A	406	345	4	12	M20	406	355	4	12	M22	406	362.0	4	12	7/8-9UNC	17.3
300A	476	390	4	12	M20	444	400	6	16	M22	476	431.8	4	12	7/8-9UNC	20

△ JAN. 7, 2011 △ JAN. 19, 2008 △ MAR. 17, 2006 △ NOV. 4, 2005

製 番 MFG. NO.				
名 称 及 形 式 NAME AND TYPE	200A~300A Type 336J-H KNIFE GATE VALVE			
番 号 NO.	部 品 名 称 PARTS NAME	材 質 MATERIAL	数 量 Q. Lty	備 考 REMARKS
1	BODY	See Table 1	1	
2	PLATE	See Table 2	1	
3	GLAND	See Table 1	1	
4	GLAND PACKING	See Table 3	1set	
5	STEM	SUS304	1	△
6	YOKE	SCS13	1	
7	SET BOLT, NUT	SUS304	2	
8	BOLT, NUT, SW	SUS304	4	
9	BOLT, NUT, SW	SUS304	4	
10	YOKE SLEEVE	CAC406	1	
11	KEY	S45C	1	
12	GREASE NIPPLE	C3601B	1	PLATED
13	THRUST BEARING	SUJ	2	
14	HAND WHEEL	FCD450	1	
15	NUT	SS400	1	PLATED
16	STEM CAP	PLASTIC	1	
17	SEAT RING	See Table 4	1	
18	SET RING	SCS14	1	
19	PACKING	NON-ASBESTOS	1	
20	SCREW	SUS304	2	
21				
22				
23				
24				
25				
日 付 DATE	OCT. 18, 2005	尺 度 SCALE	FREE	
使 用 圧 力 WORKING PRESSURE	0~1.0 MPa Pe	使 用 温 度 WORKING TEMP.	— °C	
耐 圧 試 験 SHELL TEST	1.1 MPa Pe	試 験 流 体 TEST FLUID	WATER	
弁 座 試 験 SEAT TEST	0.28 MPa Pe	許 容 漏 れ LEAKAGE	— %	
作 成 DRAWN	検 討 CHECKED	承 認 APPROVED		
	T.H	Tolce		
OKM 株式会社オーケーエム OKUMURA ENGINEERING corp.				
図 面 番 号 DRAWING NO.	336J DA 1231 ED			FLOP. No. Hd-1an975

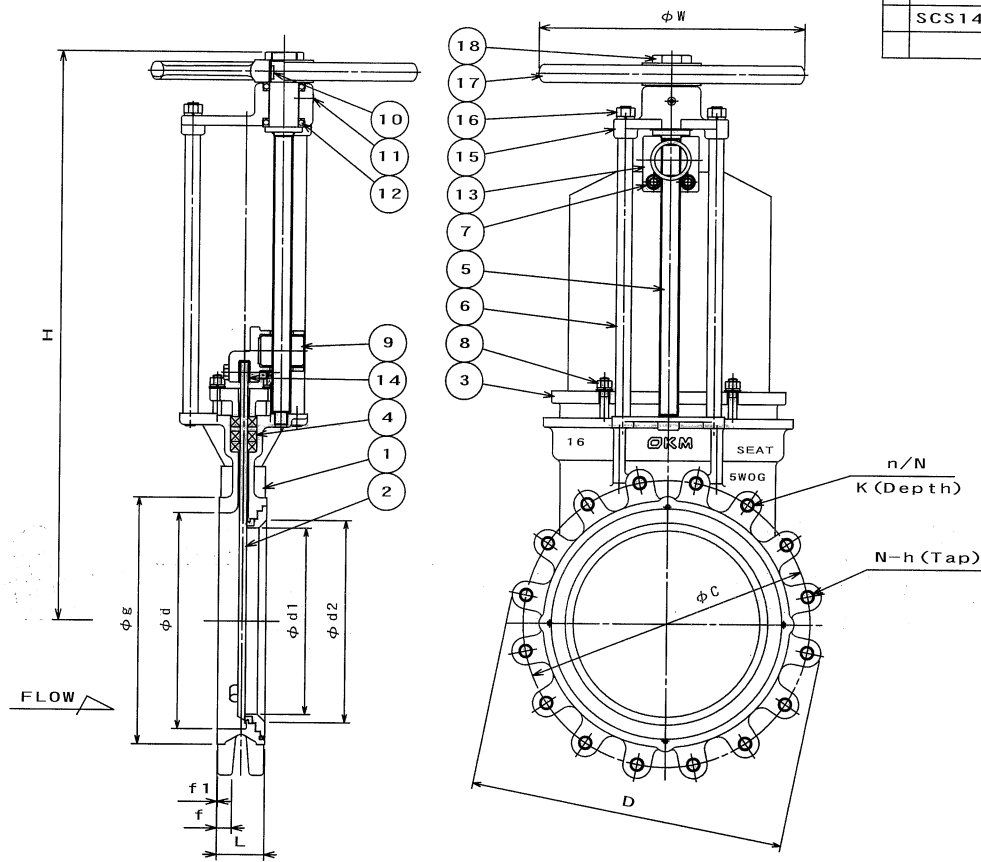
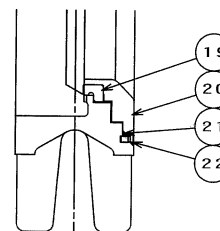

Table 1	Table 2
SCS13	SUS304
SCS14	SUS316

Table 3	Table 4
AROLAN 11 6215+Si.R #1	NBR
V#8133+Si.R	CR
	EPDM
	PTFE

*1 STANDARD



RUBBER, TEFLON SEAT

LEAKAGE
 RUBBER SEAT : 0
 TEFLON SEAT : 4cc/min X SIZE/25

注意

- 1) "FLOW" は、液体およびガスの推奨流れ方向を示します。
- 2) "N" は、片面の配管ボルト本数を示します。
- 3) 図は、400A (16インチ) を示します。
- 4) セットリングは、配管フランジにより必ずはさみ込んで下さい。配管時、セットリング側を下向けますと、セットリングが落下する恐れがあります。落下しないように注意して下さい。

ATTENTION

- 1) "FLOW" shows the liquid and gas direction of the recommendation flow.
- 2) "N" shows the plumbing bolt number of the one side.
- 3) The figure shows 400A(16in).
- 4) Set ring is fixed by the piping flanges. Set ring may, fall down while piping works, if it's side would turned to downward. Please pay your attention.

SIZE	d	d1	d2	L	g	f	f1	H	W	MASS (Approx.)
350A	356	306	340	76	406	24	1.6	950	400	92kg
400A	406	350	380	89	464	26	1.6	1071	500	115kg
450A	458	392	425	89	525	27	1.6	1161	560	145kg
500A	508	440	480	114	574	29	1.6	1312	630	204kg
550A	558	486	526	114	630	35	1.6	1411	630	236kg
600A	600	530	570	114	680	35	1.6	1514	710	293kg

SIZE	JIS5K					JIS10K					ASME125Lb/150Lb					K
	D	C	n	N	h	D	C	n	N	h	D	C	n	N	h	
350A	528	435	4	12	M22	512	445	6	16	M22	528	476.3	4	12	1-8UNC	16
400A	591	495	6	16	M22	591	510	6	16	M24	591	539.8	4	16	1-8UNC	18
450A	636	555	6	16	M22	623	565	6	20	M24	636	577.9	6	16	1 1/8-8UN	18
500A	693	605	8	20	M22	693	620	6	20	M24	693	635.0	6	20	1 1/8-8UN	22
550A	774	665	8	20	M24	774	680	8	20	M30	-	-	-	-	-	22
600A	813	715	8	20	M24	794	730	8	24	M30	813	749.3	6	20	1 1/4-8UN	24

製番
MFG. NO.

名称及形式
NAME AND TYPE

350A~600A
Type 336J-H KNIFE GATE VALVE

番号 NO.	部品名称 PARTS NAME	材質 MATERIAL	数量 Q. ty	備考 REMARKS
1	BODY	See Table 1	1	
2	PLATE	See Table 2	1	
3	GLAND	See Table 1	1	
4	GLAND PACKING	See Table 3	1set	
5	STEM	SUS304	1	
6	YOKE	SS400	4	
7	SET BOLT NUT	SUS304	2	NUT: SWRCH
8	BOLT, NUT, SW	SUS304	4	
9	SLEEVE	CAC406	1	
10	KEY	S45C	1	
11	GREASE NIPPLE	C3601B	1	PLATED
12	THRUST BEARING	SUJ	2	
13	PLATE SET	FCD450	1	
14	PLATE SET SPACER	SUS304	2	
15	ACTUATOR STAND	FCD450	1	
16	NUT, SW	SWRCH SWRH	4	PLATED
17	HAND WHEEL	FC250	1	
18	NUT	SS400	1	
19	SEAT RING	See Table 4	1	
20	SET RING	See Table 1	1	
21	PACKING	NON-ASBESTOS	1	
22	SCREW	SUS304	4	
23				
24				
25				

日付 DATE: MAR. 29, 2006 尺度 SCALE: FREE

使用圧力 WORKING PRESSURE: 0~0.5 MPa Pe 使用温度 WORKING TEMP.: - °C

耐圧試験 SHELL TEST: 0.55 MPa Pe 試験流体 TEST FLUID: WATER

弁座試験 SEAT TEST: 0.28 MPa Pe 許容漏れ LEAKAGE: - %

作成 DRAWN: MH 検討 CHECKED: T.H 承認 APPROVED: [Signature]

OKM 株式会社オーケーエム OKUMURA ENGINEERING corp.

△ MAR. 14, 2013
△ MAY 18, 2012

図面番号 DRAWING NO.: 336J DA 1401 EB FLOP. No. Hd