

# 10FUL-13A

SIZE	d	L	FLANGED								d0	l	H	W1	W2
			D	C	g	f	t	N	h						
15	1/2	20	156	95	70	51	1	12	4	15	33	70	112	R3/8	R3/8
20	3/4	20	160	100	75	56	1	14	4	15	33	70	112	R3/8	R3/8
32	1 1/4	40	230	135	100	76	2	16	4	19	63	90	158	R3/4	R3/8

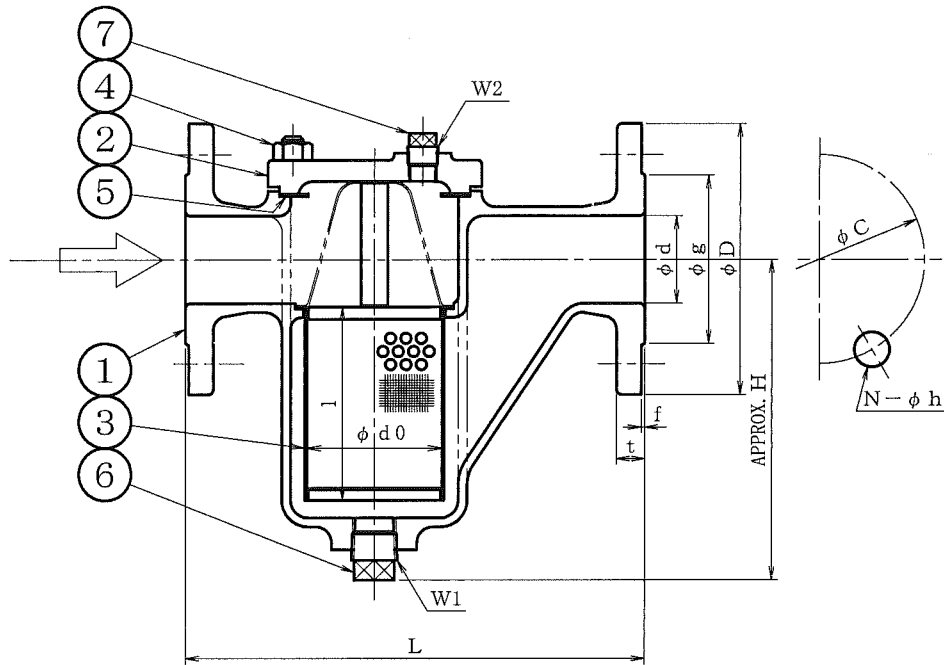
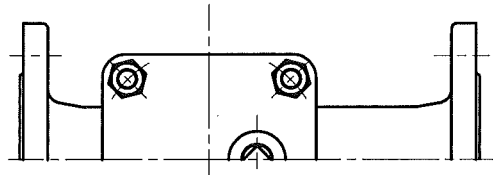

### SCREEN

	MESH
	20 MESH
	40 MESH
	60 MESH
	80 MESH
	100 MESH

No	NAME OF PART	MATERIAL	Q.T.Y	REMARKS
7	VENT PLUG	SUS304	1	
6	DRAIN PLUG	SUS304	1	
5	GASKET	T#9007-G20	1	
4	BOLT NUT	SUS304	SET	
3	SCREEN	SUS304	1	
2	COVER	SCS13A	1	
1	BODY	SCS13A	1	

NAME 10K

### FLANGED U TYPE STRAINER

FLUID		TEST PRESSURE	BODY	(HYD) 1.5 MPaG
DESIGN PRESSURE	1.0 MPaG		SEAT	(AIR) MPaG
DESIGN TEMPERATURE	150 °C			(HYD) MPaG
				(AIR) MPaG

DRAWING No

MODEL No 10FUL-13A

DATE

A. P

C. K

D. S

D. W

FEB. 24, 2012

MORITA

MORITA

MORITA

MORIE

No	DESCRIPTION	DATE	A. P	C. K	D. W
REVISIONS					

# 10FUL-13A

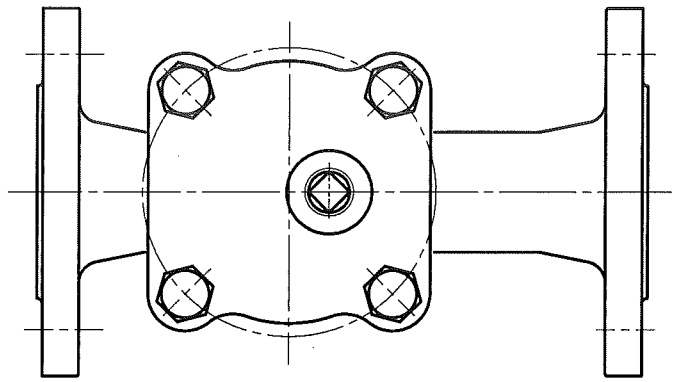

SIZE	d	L	FLANGED								d0	l	H	W1	W2
			D	C	g	f	t	N	h						
25	1	25	180	125	90	67	1	14	4	19	43	80	130	R1/2	R3/8
40	1 1/2	40	230	140	105	81	2	16	4	19	63	90	158	R3/4	R3/8
50	2	50	260	155	120	96	2	16	4	19	78	110	183	R3/4	R3/8

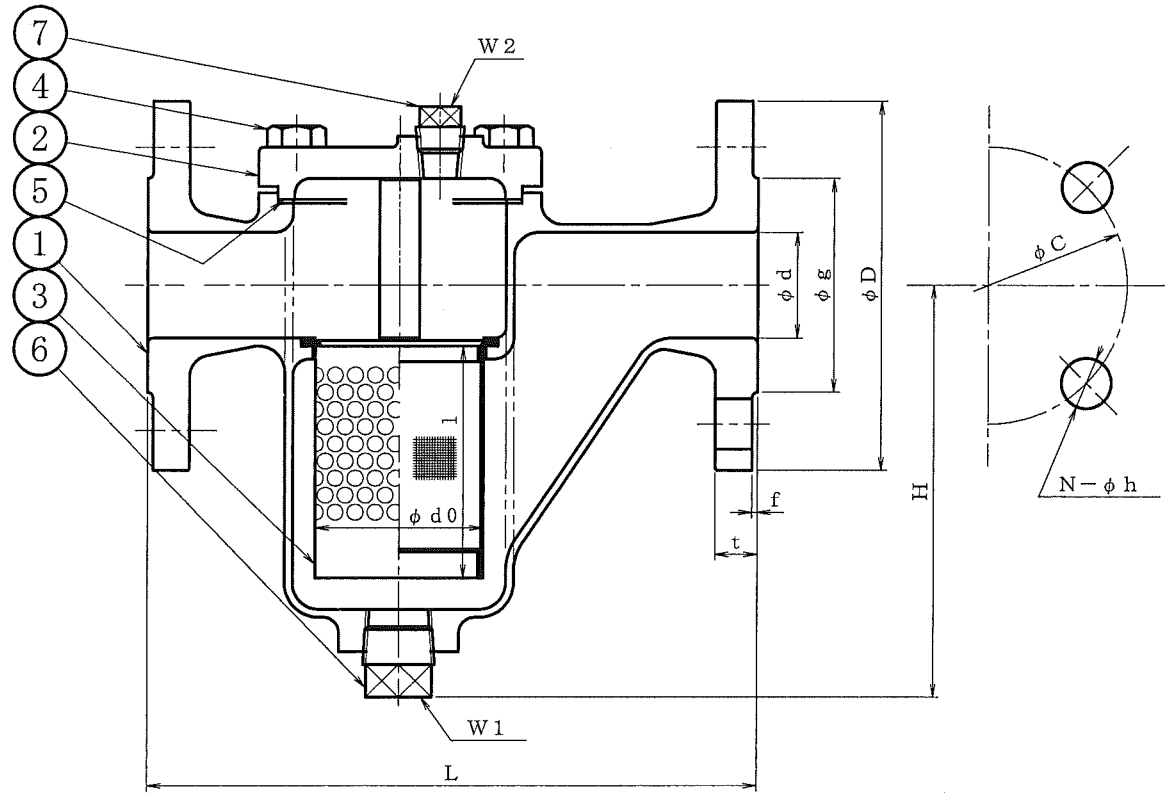

SCREEN	
	MESH
	20 MESH
	40 MESH
	60 MESH
	80 MESH
	100 MESH

No	NAME OF PART	MATERIAL	Q.T.Y	REMARKS
7	VENT PLUG	SUS304	1	
6	DRAIN PLUG	SUS304	1	
5	GASKET	T#9007-G20	1	
4	BOLT	SUS304	4	
3	SCREEN	SUS304	1	
2	COVER	SCS13A	1	
1	BODY	SCS13A	1	

NAME 10K				
FLANGED U TYPE STRAINER				
FLUID		TEST PRESSURE	BODY	(HYD) 1.5 MPaG (AIR) MPaG
DESIGN PRESSURE	1.0 MPaG		SEAT	(HYD) MPaG (AIR) MPaG
DESIGN TEMPERATURE	150 °C			(HYD) MPaG (AIR) MPaG

DRAWING No			MODEL No 10FUL-13A	
DATE	A. P	C. K	D. S	D. W
FEB. 24, 2012	MORITA	MORITA	MORITA	HORIE

No	DESCRIPTION	DATE	A. P	C. K	D. W
REVISIONS					

# 10FUL-13A

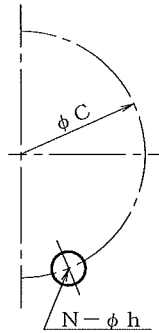
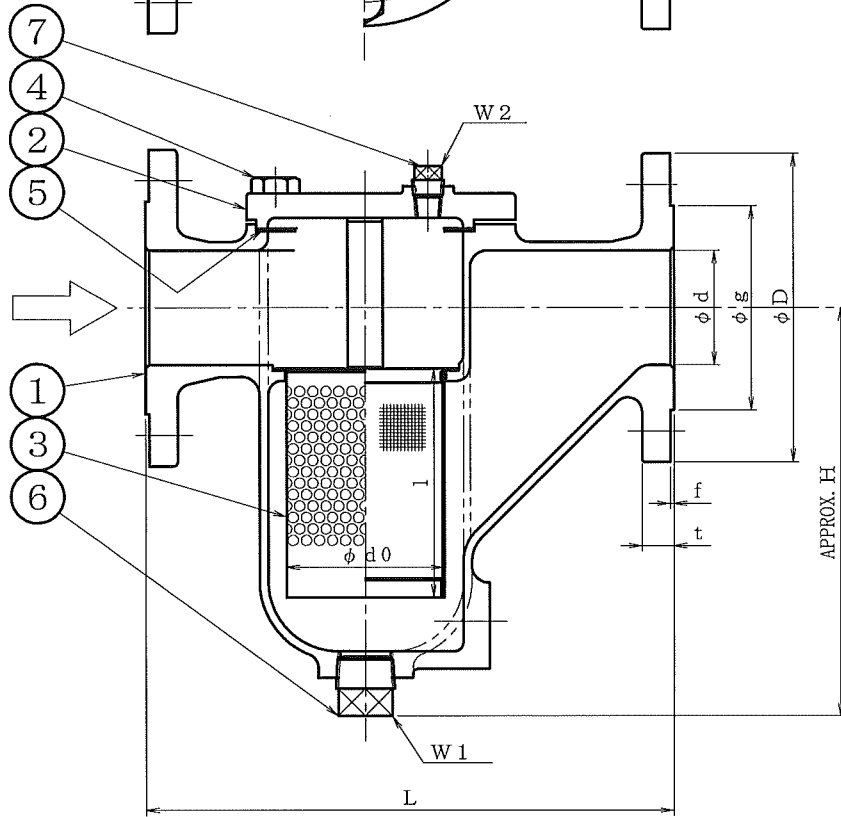
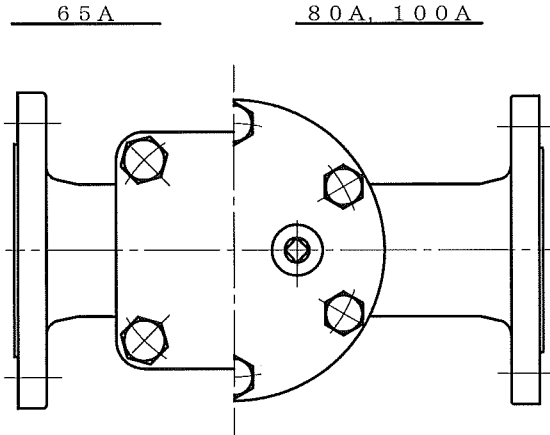

SIZE	d	L	FLANGED								d0	l	H	W1	W2
			D	C	g	f	t	N	h						
65	2 1/2	65	300	175	140	116	2	18	4	19	90	130	235	R1	R3/8
80	3	80	350	185	150	126	2	18	8	19	104	150	265	R1	R3/8
100	4	100	400	210	175	151	2	18	8	19	132	190	330	R1	R3/8

### SCREEN

	MESH
	20 MESH
	40 MESH
	60 MESH
	80 MESH
	100 MESH

No	NAME OF PART	MATERIAL	Q.T.Y	REMARKS
7	VENT PLUG	SUS304	1	
6	DRAIN PLUG	SUS304	1	
5	GASKET	T#9007-G20	1	
4	BOLT	SUS304	SET	
3	SCREEN	SUS304	1	
2	COVER	SCS13A	1	
1	BODY	SCS13A	1	

NAME 10K  
FLANGED U TYPE STRAINER

FLUID	DESIGN PRESSURE	DESIGN TEMPERATURE	TEST PRESSURE	BODY	SEAT
	1.0 MPaG	150 °C		(HYD) 1.5 MPaG (AIR) MPaG	(HYD) MPaG (AIR) MPaG
				(HYD) MPaG (AIR) MPaG	(HYD) MPaG (AIR) MPaG

DRAWING No MODEL No 10FUL-13A

DATE	A. P	C. K	D. S	D. W
2013. 8. 30	MORITA	MORITA	MORITA	HISAKA

**MMM** THREE-M INDUSTRY CO.,LTD.

No	DESCRIPTION	DATE	A. P	C. K	D. W
REVISIONS					

# 10FUL-13A

SIZE	d	L	FLANGED								d0	l	H	H1	W1	W2
			D	C	g	f	t	N	h							
125	5	490	250	210	182	2	20	8	23	162	250	400	204	R1	R1/2	
150	6	560	280	240	212	2	22	8	23	202	300	500	218	R1	R1/2	

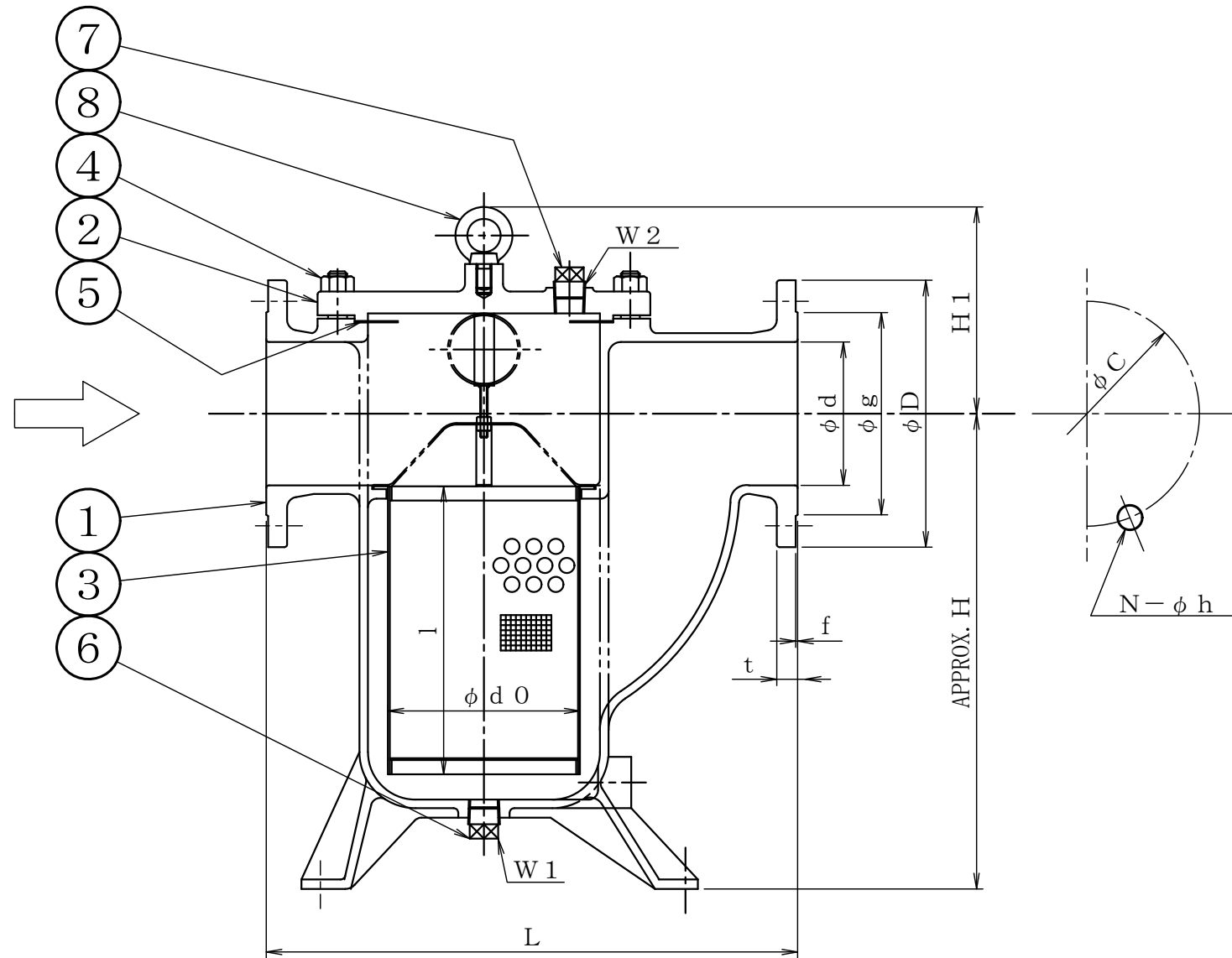
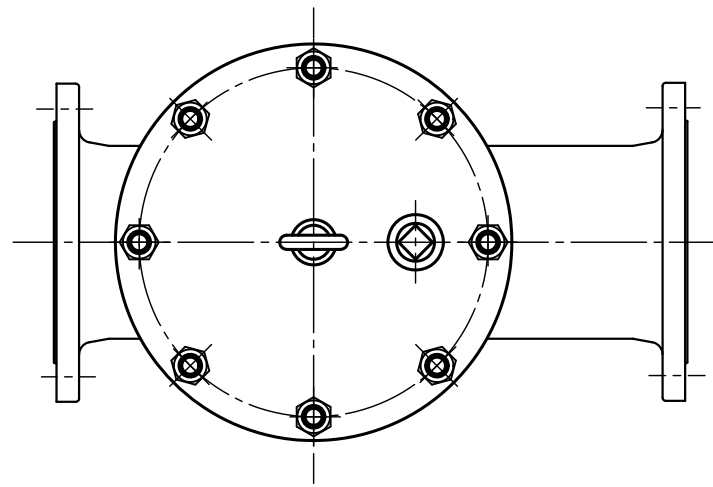

### SCREEN

	MESH
	20 MESH
	40 MESH
	60 MESH
	80 MESH
	100 MESH

8	EYE BOLT	SUS304	1	
7	VENT PLUG	SUS304	1	
6	DRAIN PLUG	SUS304	1	
5	GASKET	T#9007-G20	1	
4	BOLT NUT	SUS304	SET	
3	SCREEN	SUS304	1	
2	COVER	SCS13A	1	
1	BODY	SCS13A	1	
No	NAME OF PART	MATERIAL	Q.T.Y	REMARKS

NAME 10K  
FLANGED U TYPE STRAINER

FLUID		TEST PRESSURE	BODY	(HYD) 1.5 MPaG
			SEAT	(AIR) MPaG
DESIGN PRESSURE	1.0 MPaG			(HYD) MPaG
DESIGN TEMPERATURE	150 °C			(AIR) MPaG

DRAWING No \_\_\_\_\_ MODEL No 10FUL-13A

DATE	A. P	C. K	D. S	D. W
SEP. 12, 2014	MORITA	MORITA	MORITA	HISAKA

**MM** THREE-M INDUSTRY CO.,LTD.

No	DESCRIPTION	DATE	A. P	C. K	D. W
REVISIONS					