

# 10FGL-2-13A

SIZE	d	L	FLANGED								H	E	F	T
			D	C	g	f	t	N	h					
15	1/2	15	130	95	70	51	1	12	4	15	72	40	50	6
20	3/4	20	130	100	75	56	1	14	4	15	72	40	50	6
25	1	25	150	125	90	67	1	14	4	19	88	50	65	8
40	1 1/2	40	170	140	105	81	2	16	4	19	116	65	80	10
50	2	50	200	155	120	96	2	16	4	19	135	80	95	12

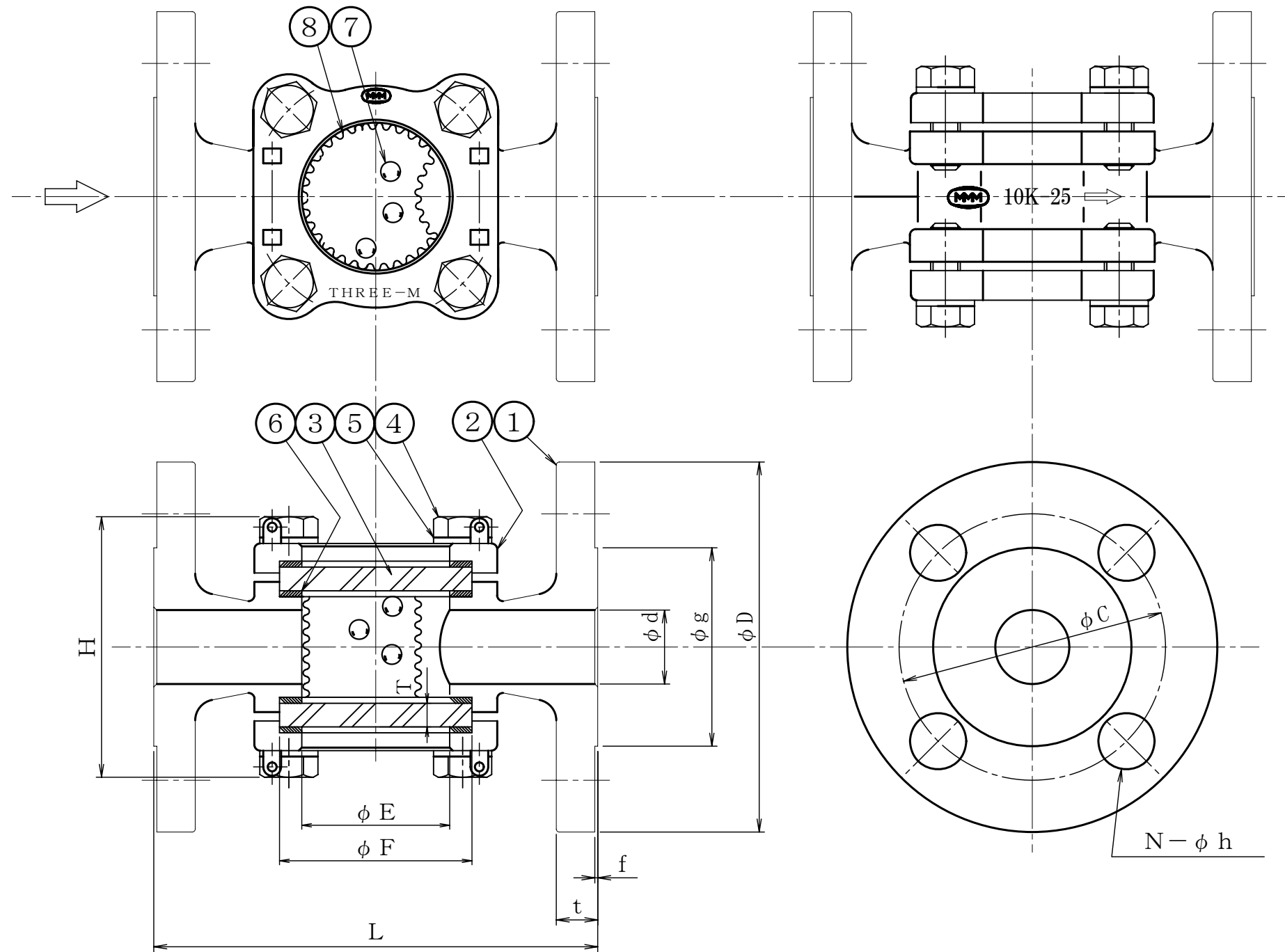

8	SCREEN	SUS304	1	
7	BALL	POLYPROPYLEN	SET	
		ACRYL		
6	GASKET	T#9007-G20	4	
5	WASHER	SUS304	8	
4	BOLT	SUS304	8	
3	GLASS	TEMPERED GLASS	2	
2	COVER	SCS13A	2	
1	BODY	SCS13A	1	
No	NAME OF PART	MATERIAL	Q.T.Y	REMARKS

NAME 10K BALL TYPE  
FLANGED SIGHT GLASS

FLUID		TEST PRESSURE	BODY	(HYD) 1.5 MPaG
			SEAT	(AIR) MPaG
DESIGN PRESSURE	1.0 MPaG			(HYD) MPaG
DESIGN TEMPERATURE	85 °C			(AIR) MPaG

DRAWING No \_\_\_\_\_ MODEL No 10FGL-2-13A

DATE	A. P	C. K	D. S	D. W
APR. 11, 2012	MORITA	MORITA	MORITA	HORIE

**MM** THREE-M INDUSTRY CO.,LTD.

No	DESCRIPTION	DATE	A. P	C. K	D. W
REVISIONS					

# 10FGL-2-13A

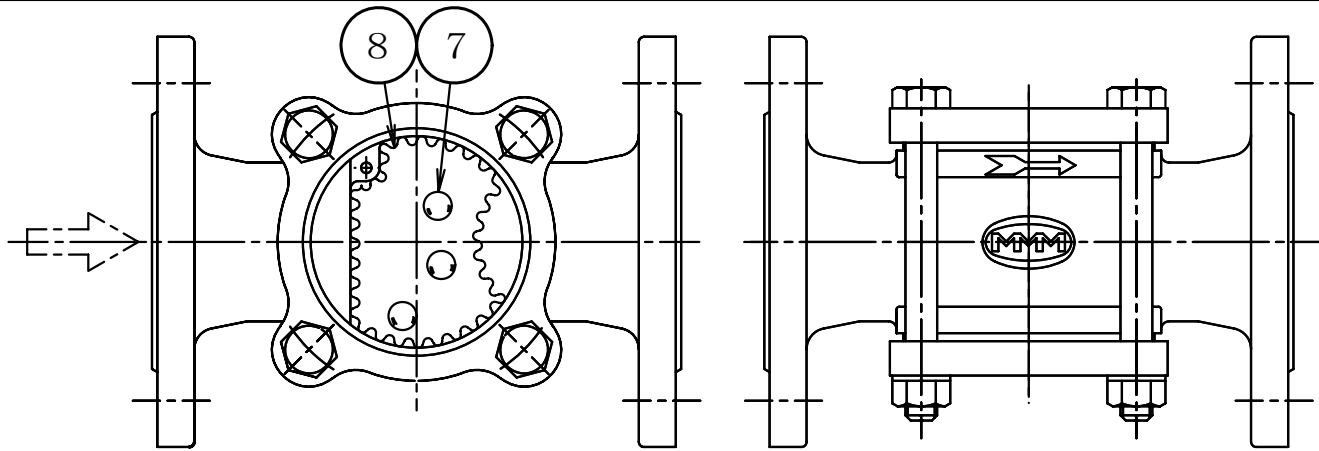

SIZE	d	L	FLANGED								H	E	F	T
			D	C	g	f	t	N	h					
10	3/8	15	130	90	65	46	1	12	4	15	65	40	50	6
32	1 1/4	40	170	135	100	76	2	16	4	19	110	65	80	10
65	2 1/2	65	270	175	140	116	2	18	4	19	176	120	140	19
80	3	80	270	185	150	126	2	18	8	19	176	120	140	19
100	4	100	320	210	175	151	2	18	8	19	206	155	180	22

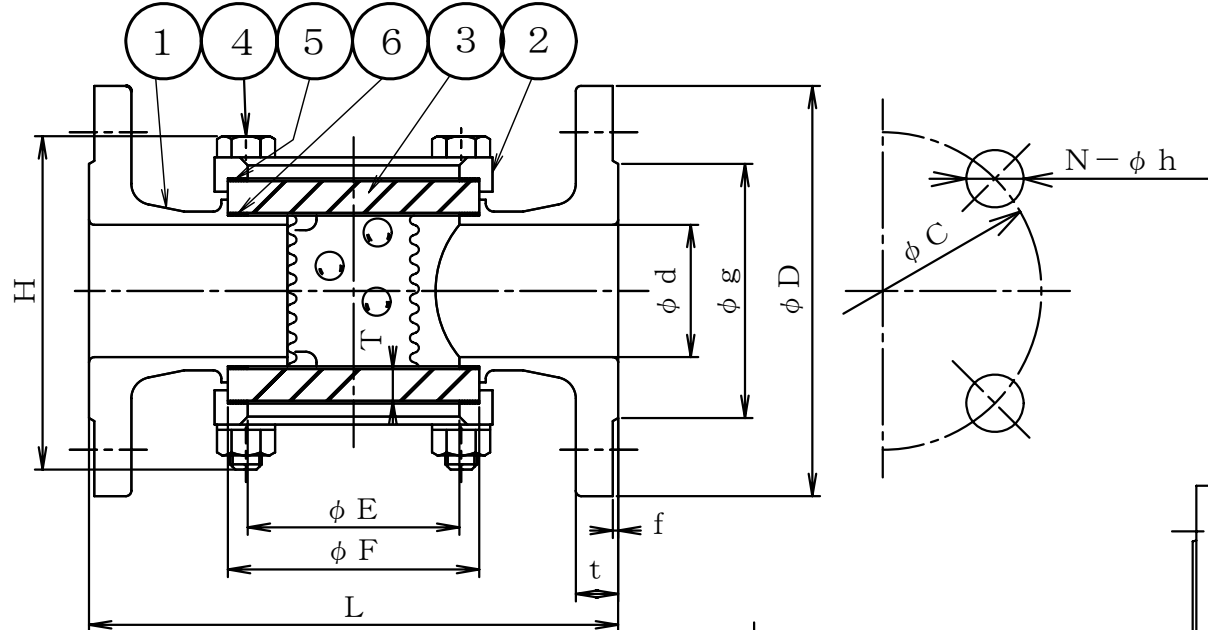

10A, 32A

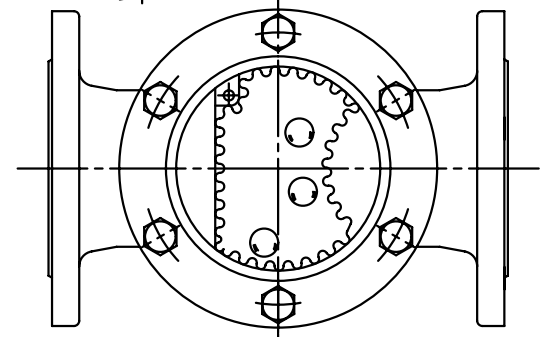

65A, 80A

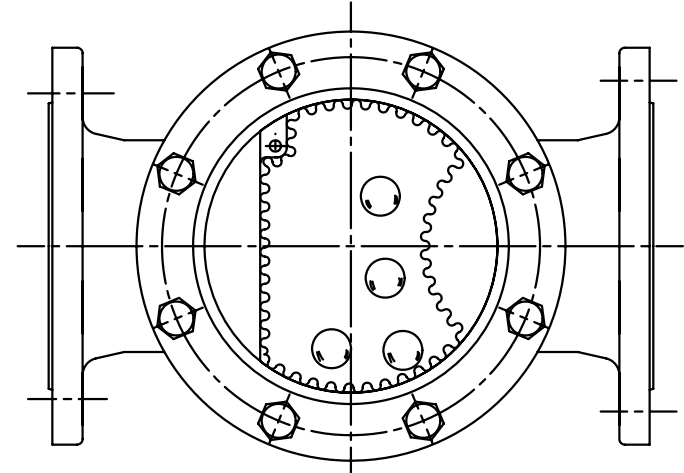

100A

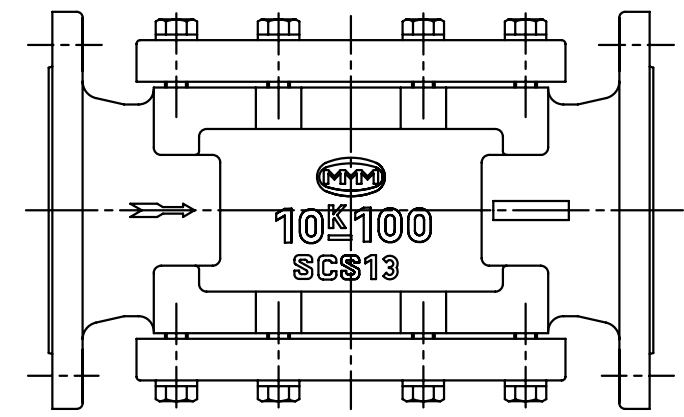

No	NAME OF PART	MATERIAL	Q.T.Y	REMARKS
8	SCREEN	SUS304	1	
7	BALL	POLYPROPYLEN	SET	
		ACRYL		
6	GASKET	T#9007-G20	2	
5	GASKET	T#9007-G20	2	
4	BOLT NUT WASHER	SUS304	SET	
3	GLASS	TEMPERED GLASS	2	
2	COVER	SCS13A	2	
1	BODY	SCS13A	1	

NAME 10K BALL TYPE  
FLANGED SIGHT GLASS

FLUID	DESIGN PRESSURE	DESIGN TEMPERATURE	TEST PRESSURE	BODY	SEAT
	1.0 MPaG	85 °C		(HYD) 1.5 MPaG (AIR) MPaG	(HYD) MPaG (AIR) MPaG

DRAWING No \_\_\_\_\_ MODEL No 10FGL-2-13A

DATE	A.P	C.K	D.S	D.W
APR. 11, 2012	MORITA	MORITA	MORITA	HORIE

**MM THREE-M INDUSTRY CO.,LTD.**

No	DESCRIPTION	DATE	A.P	C.K	D.W
REVISIONS					