

7	Nut	Rolled Steel	六角ナット	SS400	4
6	Bolt	Carbon Steel	六角ボルト	SCM435	4
4	Gasket	Non-Asbestos	ガスケット	Non-Asbestos	4
3	Glass	Tempered Glasses	ガラス	強化ガラス	2
2	Cover	Ductile Cast Iron	ふた	FCD450	2
1	Body	Ductile Cast Iron	本体	FCD450	1
No.	Name of Parts	Material	部品名	材質	Q. TY

Size	L	A	B	W	Flange JIS 10KFF (mm)					Weight (kg)
					d	D	C	t	n-h	
65A	235	178	140	97	65	175	140	22	4-19	14.7
80A	235	188	140	97	73	185	150	22	8-19	15.1

Specification	
Fluid	
Press.	MPa
Temp.	℃

TYPE 150L-F SIGHT GLASS
サイトグラス

Approval	H. Iwamoto
Check	M. Yoshida
Drawing	H. Okumura
Drawing No.	Y-469-6505-2A
Date	17 OCT.2012



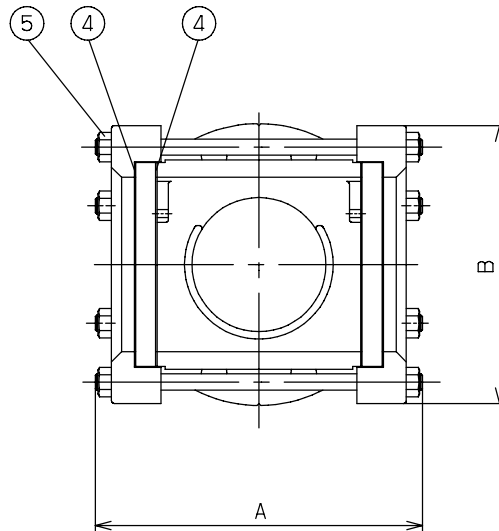
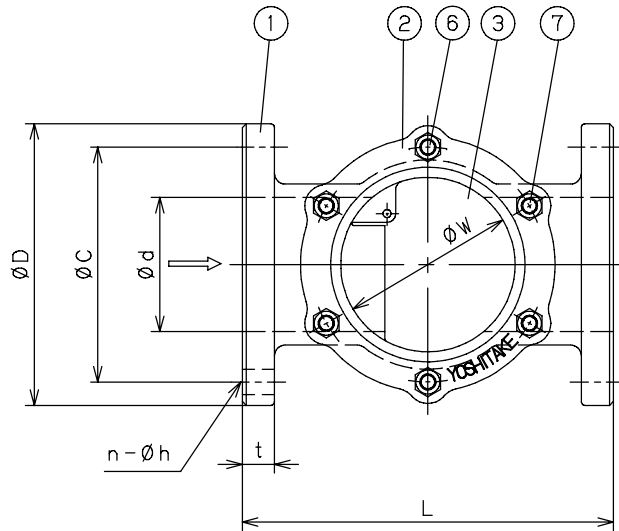
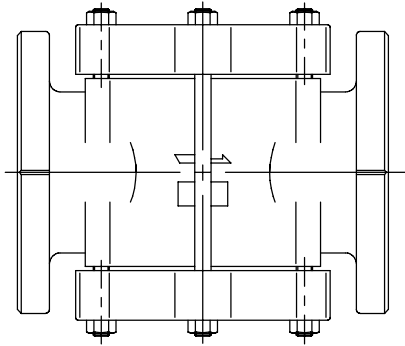

7	Stud Bolt	Rolled Steel	スタットボルト	SS400	1set
6	Stud Bolt	Rolled Steel	スタットボルト	SS400	1set
5	Nut	Rolled Steel	六角ナット	SS400	1set
4	Gasket	Non-Asbestos	ガスケット	Non-Asbestos	4
3	Glass	Tempered Glasses	ガラス	強化ガラス	2
2	Cover	Ductile Cast Iron	ふた	FCD450	2
1	Body	Ductile Cast Iron	本体	FCD450	1
No.	Name of Parts	Material	部品名	材質	Q.TY

Size	L	A	B	W	(mm)					Weight (kg)
					Flange JIS 10KFF					
					d	D	C	t	n-h	
100A	277	244	207	130	100	210	175	24	8-19	26.5
125A	336	248	220	155	125	250	210	24	8-23	36.8
150A	380	304	270	165	140	280	240	26	8-23	60.5

Specification	
Fluid	
Press.	MPa
Temp.	°C

TYPE 150L-F SIGHT GLASS
サイトグラス

Approval	T. Nishiyama
Check	H. Iwamoto
Drawing	Y. Shibata
Drawing No.	Y-0469-6505
Date	26 APR. 2008

