

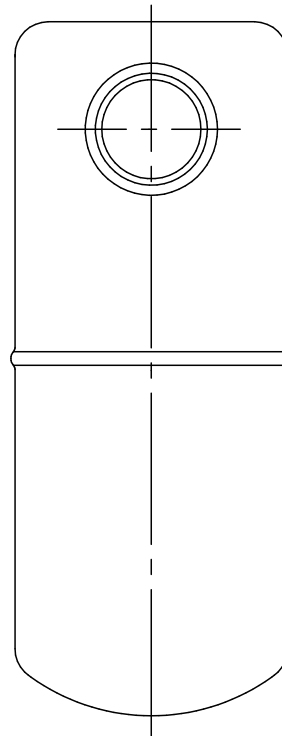

※1811-1.0は20Aのみ製作致します。

Model 型式	※1811-1.0	1811-2.1	1811-4.9	1811-8.7	1811-14	1811-17.5	1811-28
Orifice Size オリフィスサイズ (inch)	1/4 (6.4mm)	3/16 (4.8mm)	5/32 (4.0mm)	1/8 (3.2mm)	7/64 (2.8mm)	#38 (2.5mm)	5/64 (2.0mm)
Maximum Differential Pressure 最高作動圧力差 (MPa)	0.10	0.21	0.49	0.87	1.40	1.75	2.80

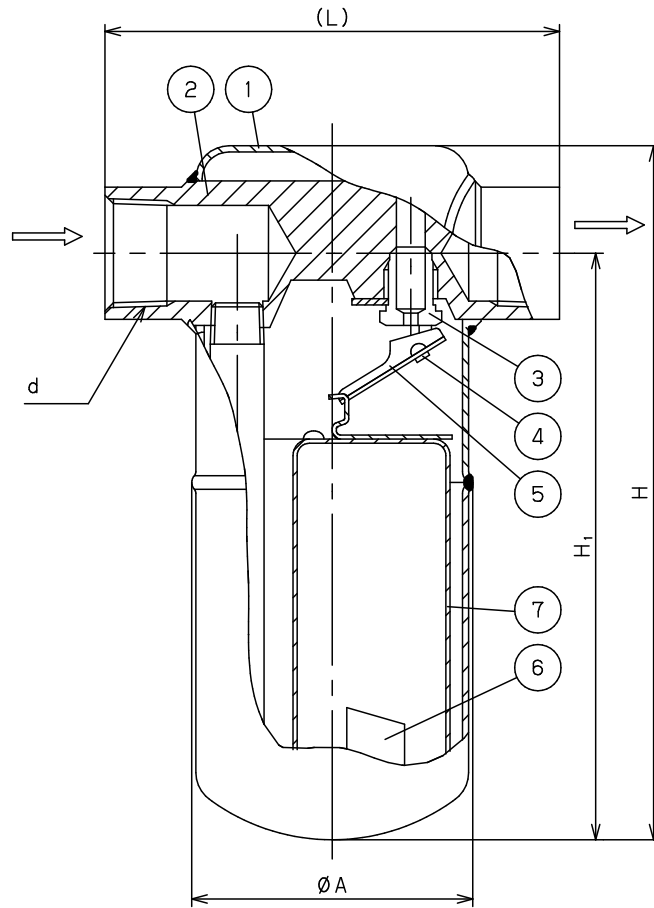

7	Bucket	バケット	ASTM A240 T304	1
6	Pipe	入口案内管	ASTM A312 T304L	1
5	Lever	レバー	Alloy 20CB-3	1
4	Valve	弁体	ASTM A582 T440F	1
3	Valve Seat	弁座	ASTM A582 T440F	1
2	Joint	接続継手	ASTM A479 T304	1
1	Body	本体	ASTM A240 T304L	1
No.	Name of Parts	部品名	Material	Q. TY

(mm)

Size	d	L	H	H <sub>1</sub>	A	Weight (kg)
15A	Rc 1/2	110	160	138	68	0.9
20A	Rc 3/4	110	167	141	68	1.0

Specification	
Fluid	
Press.	MPa
Temp.	℃

TYPE 1811 STEAM TRAP  
スチームトラップ

Approval	H. Kimura
Check	Y. Aoyama
Drawing	T. Inose
Drawing No.	Y-360-3601-1B
Date	5 APR. 2017

**Yoshitake**  
INC.