

12	Scale Plate	Aluminium	指示板	A1050	1
11	Scale Plate	Aluminium	指示板	A1050	1
10	Spindle	Stainless Steel	スピンドル	SUS304	1
9	Flap Spring	Stainless Steel	フラップばね	SUS304	1
8	Flap	Stainless Steel	フラップ	SUS304	1
7	Spring Washer	Carbon Steel	ばね座金	SWRH	4
6	Nut	Carbon Steel	六角ナット	S25C or S45C	4
5	Bolt	Carbon Steel	六角ボルト	SCM435	4
4	Gasket	Non-Asbestos	ガスケット	Non-Asbestos	2
3	Glass	Tempered Glasses	ガラス	強化ガラス	2
2	Cover	Ductile Cast Iron	ふた	FCD450	2
1	Body	Ductile Cast Iron	本体	FCD450	1
No.	Name of Parts	Material	部品名	材質	Q. TY

(mm)					
Size	d	L	A	W	Weight (kg)
15A	Rc 1/2	80	79.0	35	0.7
20A	Rc 3/4	90	79.0	35	0.8
25A	Rc 1	115	100.5	44	1.4

Specification	
Fluid	
Press.	MPa
Temp.	℃

TYPE SF-1S SIGHT GLASS
サイトグラス

Approval	H. Iwamoto
Check	M. Yoshida
Drawing	H. Okumura
Drawing No.	Y-828-6501-5A
Date	11 SEP. 2012

Joshitake
INC.

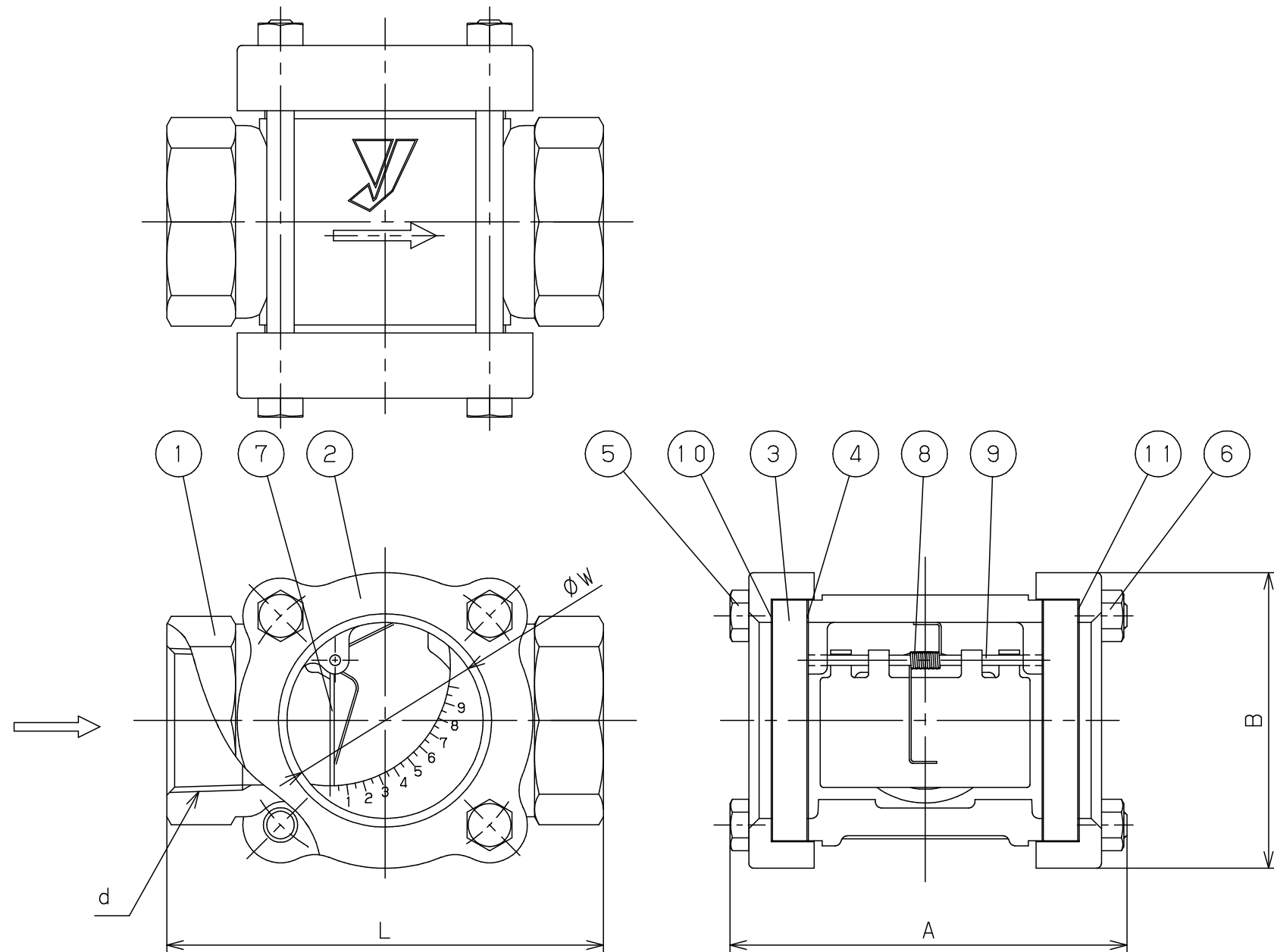

11	Scale Plate	Aluminium	指示板	A1050	1
10	Scale Plate	Aluminium	指示板	A1050	1
9	Spindle	Stainless Steel	スピンドル	SUS304	1
8	Flap Spring	Stainless Steel	フラップばね	SUS304	1
7	Flap	Stainless Steel	フラップ	SUS304	1
6	Nut	Carbon Steel	六角ナット	S45C	4
5	Bolt	Carbon Steel	六角ボルト	SCM435	4
4	Gasket	Non-Asbestos	ガスケット	Non-Asbestos	2
3	Glass	Tempered Glasses	ガラス	強化ガラス	2
2	Cover	Ductile Cast Iron	ふた	FCD450	2
1	Body	Ductile Cast Iron	本体	FCD450	1
No.	Name of Parts	Material	部品名	材質	Q. TY

Size	d	L	A	B	W	Weight (kg)
32A	Rc 1 1/4	127	120.5	86	57	2.5
40A	Rc 1 1/2	140	120.5	86	57	2.8
50A	Rc 2	162	147	114	73	5.4

Specification	
Fluid	
Press.	MPa
Temp.	℃

TYPE SF-1S SIGHT GLASS
フラップ式サイトグラス

Approval	H. Iwamoto
Check	M. Yoshida
Drawing	H. Okumura
Drawing No.	Y-828-6501-3A
Date	7 SEP. 2012