

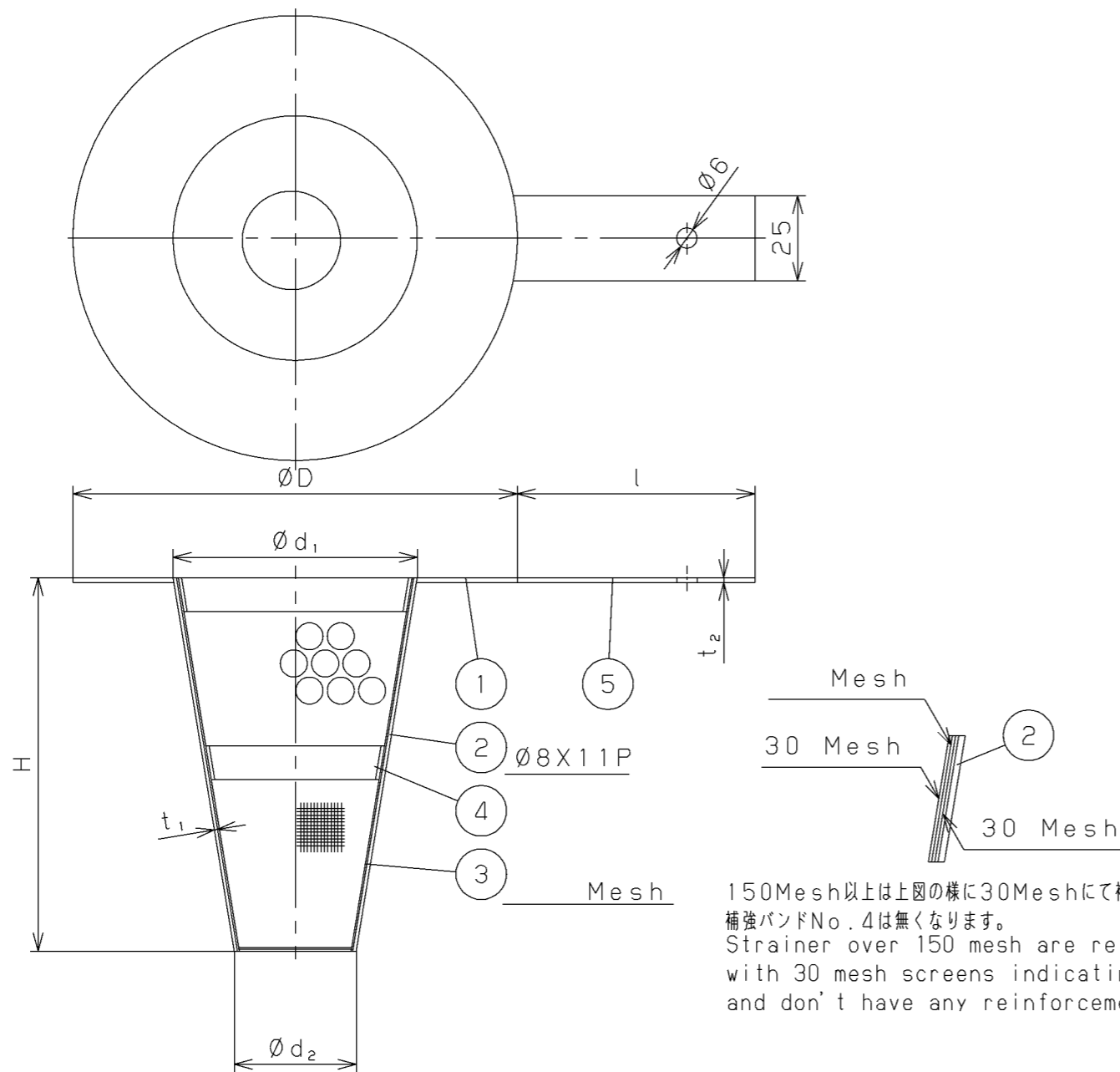

80A~300A

但し、80A~125Aは、中間補強バンドは無くなります。

80A~125A Strainers have only upper reinforcement band and lower one, not intermediate one.



150Mesh以上は上図の様に30Meshにて補強し、補強バンドNo. 4は無くなります。
Strainer over 150 mesh are reinforced with 30 mesh screens indicating above, and don't have any reinforcement bands.

Size	d ₁	d ₂	H	l	t ₁	Flange JIS 10K	
						D	t ₂
25A	24	---	46	65	1.0	71	1.5
32A	30	---	55	65	1.0	81	1.5
40A	38	---	73	65	1.0	86	1.5
50A	48	---	93	65	1.0	101	1.5
65A	60	---	118	65	1.0	121	1.5
80A	72	36	110	70	1.0	131	1.5
100A	95	48	135	70	1.0	156	1.5
125A	118	60	165	70	1.0	187	2.0
150A	142	72	195	85	1.0	217	2.0
200A	188	95	250	85	1.0	267	2.0
250A	235	119	330	85	1.0	330	2.0
300A	280	141	395	85	1.0	375	2.0

25A~65A

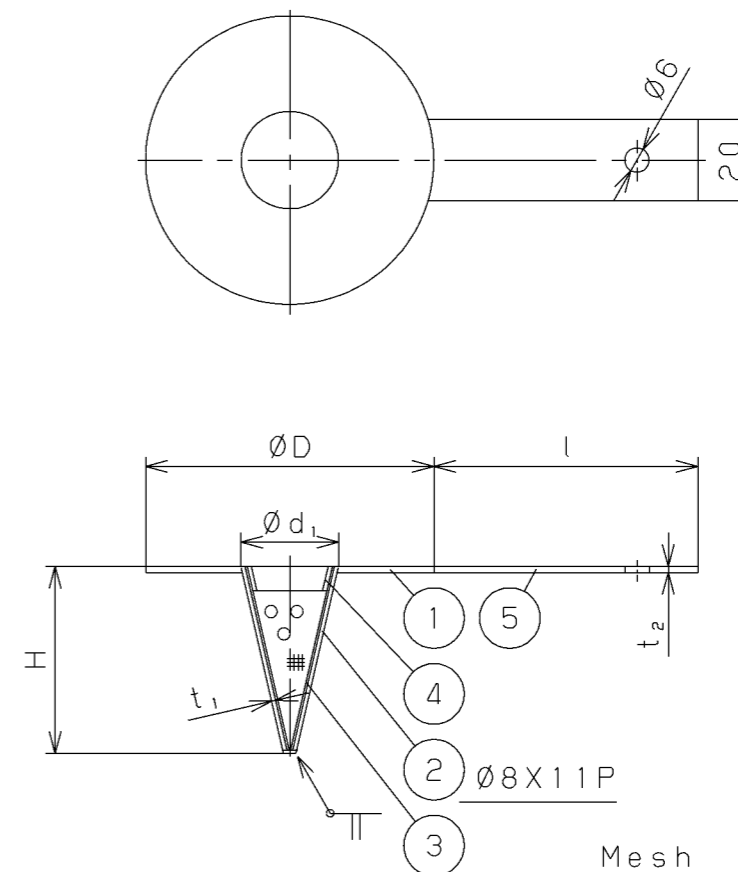

No.	Name of Parts	Material	部品名	材質	Q. TY
5	Indicator	Stainless Steel	インジケター	SUS304	1
4	Reinforcement Band	Stainless Steel	補強バンド	SUS304	1~2
3	Inside Screen	Stainless Steel	内網	SUS304	1
2	Outside Screen	Stainless Steel	外網	SUS304	1
1	Flange	Stainless Steel	フランジ	SUS304	1

Specification	
Fluid	
Press.	MPa
Temp.	℃
Flow Rate	
Inside Screen	Mesh
Outside Screen	Ø - ㄎ/cm ²

TYPE ST-1 STRAINER ストレーナ

Approval	H. Iwamoto
Check	Y. Aoyama
Drawing	H. Kamada
Drawing No.	Y-036-3505-3A
Date	20 MAR. 2015

