

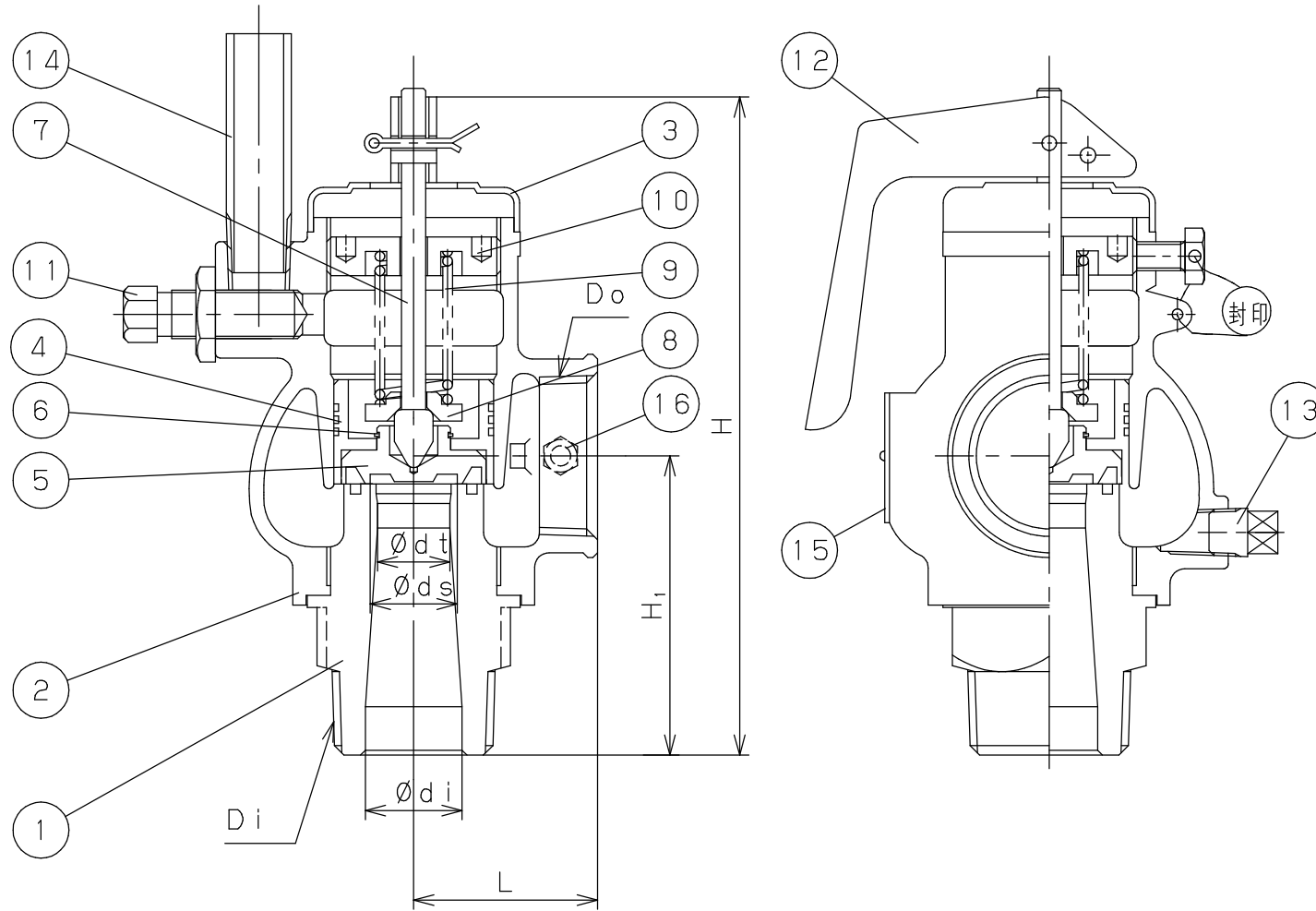

注意

当図面には、秘密情報など法的に守られた
 情報を含んでいる場合があります。
 当図面を用いての試作・量産品の製作、並びに
 第三者への内容・情報の開示等を禁止します。
 株式会社 ヨシタケ



16	Bolt	Rolled Steel	六角ボルト	SS400	1
15	Name Plate	Stainless Steel	銘板	SUS304	1
14	Pipe	Carbon Steel Pipe	背圧パイプ	SGP	1
13	Plug	Rolled Steel or Carbon Steel	プラグ	SS400 or S15C	1
12	Lever	Stainless Steel	レバー	SUS430	1
11	Needle Valve	Brass	背圧絞り弁	C3604	1
10	Adjusting Screw	Brass	調節ねじ	C3604	1
9	Spring	Piano Wire or Alloy Steel	ばね	SWP or SWOSC or SWOCV	1
8	Spring Plate	Brass	ばね受	C3604	1
7	Spindle	Stainless Steel	弁棒	SUS403	1
6	Retaining Ring C TYPE	Stainless Steel	C形止め輪	SUS304	1
5	Valve	Stainless Steel	弁体	SUS630	1
4	Valve guide	Brass	弁体ガイド	C3604	1
3	Cover	Stainless Steel	カバー	SUS430	1
2	Spring Chamber	Bronze	ばね箱	CAC406	1
1	Valve Seat	Stainless Steel or Cast Stainless Steel	弁座	SUS403 or SCS2	1
No.	Name of Parts	Material	部品名	材質	Q. TY

(mm)

Size	dt	ds	LIFT	di	Di	Do	L	H	H1	Plug	Weight (kg)
20A	15	18	3.3	20	R 1	Rc 1	38	136	61	R 1/8	1.24
25A	19	22	4.4	25	R 1 1/4	Rc 1 1/4	45	157	70	R 1/8	1.88
32A	24	28	5.5	32	R 1 1/2	Rc 1 1/2	52	183	80	R 1/8	2.62
40A	30	35	6.8	40	R 2	Rc 2	65	216	98	R 1/4	5.10
50A	38	44	8.7	50	R 2 1/2	Rc 2 1/2	77	262	121	R 1/4	8.40

Specification	
Fluid	
Set Press.	MPa
Temp.	℃
Flow Rate	

TYPE AF-5 FULL BORE SAFETY VALVE 全量式安全弁	
Approval	T. Watanabe
Check	T. Mori
Drawing	T. Nagasaka
Drawing No.	Y-222-1801-8A
Date	11 JUN. 2021

