

(mm)

Size	L	L ₁	L ₂	H ₁	H ₂	d ₁	d _o	d _s	l _s	Flange JIS10KFF equivalent (相当)				Weight (kg)	
										d	D	C	t		
50A	243	105	138	166	88	R1/4	R3/4	64.5	108	50	155	120	※20	4-19	13.0
65A	254	106	148	166	88	R1/4	R3/4	64.5	108	65	175	140	※20	4-19	15.0
80A	300	124	176	204	98	R3/8	R1	77	140	80	185	150	※22	8-19	20.0
100A	315	142	173	230	103	R3/8	R1	90	160	100	210	175	※24	8-19	29.0
150A	455	190	265	385	137	R3/8	R1 1/2	140	270	150	280	240	※28	8-23	73.5

※フランジ厚みは規格より厚くなっております。
 ※Thickness of Flange is thicker than standard type.

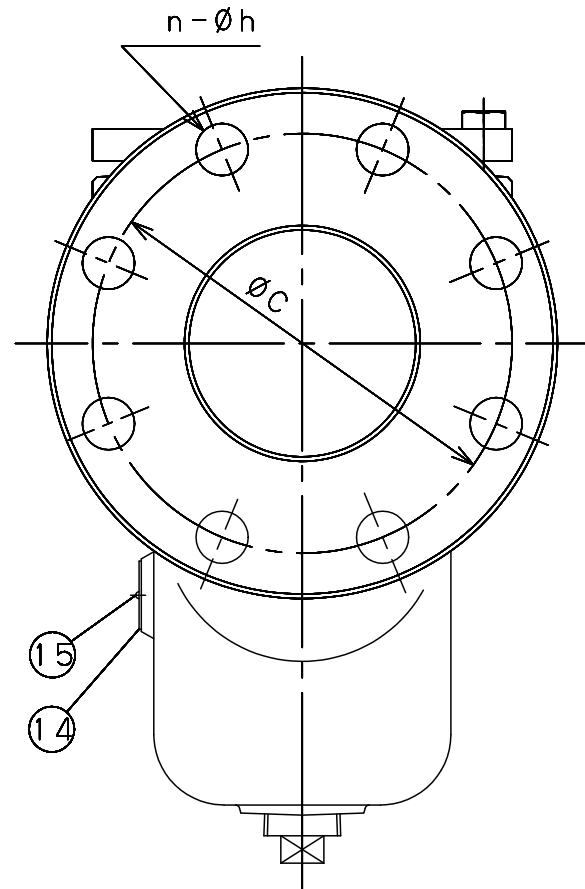
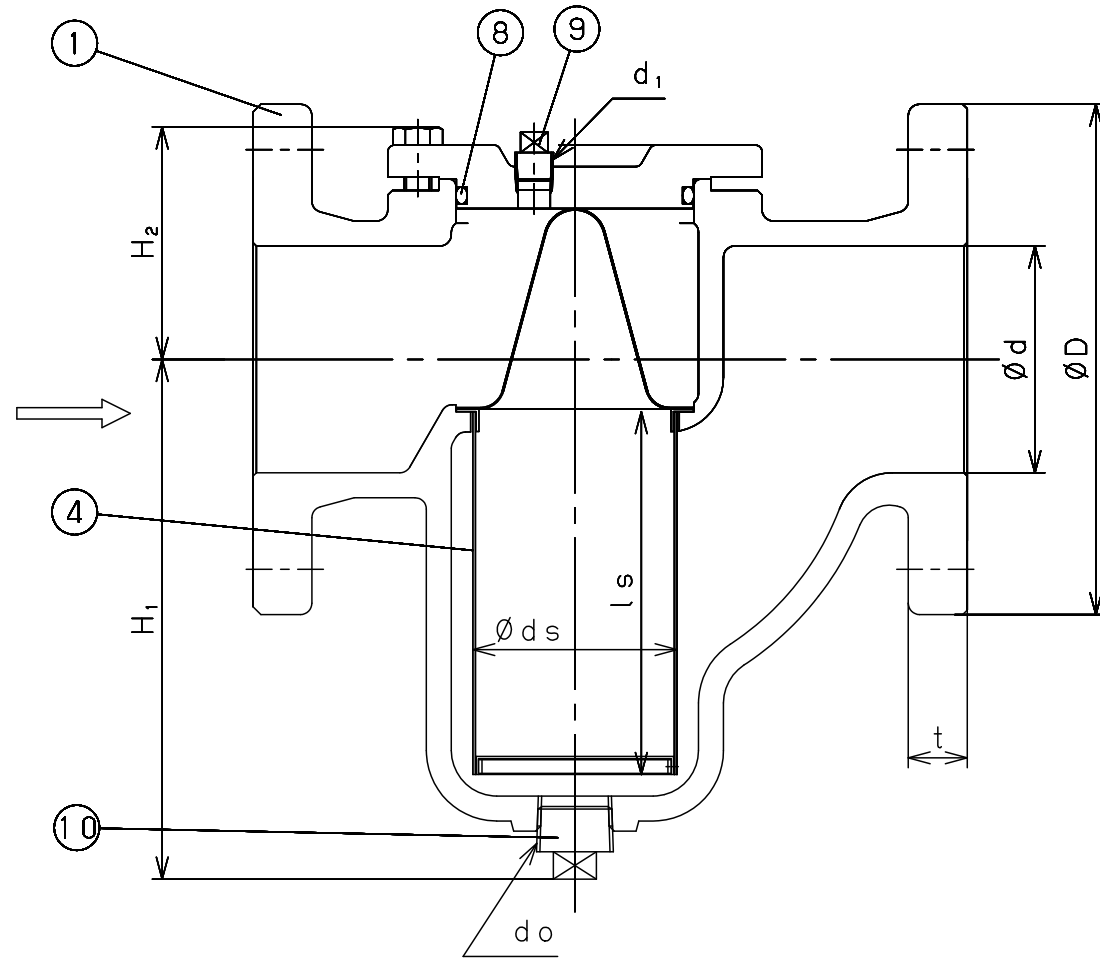

注) ②ふた及び④スクリーンの取手は、サイズにより形状が異なります。
 Shape of ②Cover and ④Screen's Grip is different according to size.

15 Rivets	Carbon Steel	打込みねじ	S15C	2
14 Plate	Aluminium	銘板	A1050P	1
10 Plug	Malleable Cast Iron	プラグ	FCMB310	1
9 Plug	Rolled Steel or Malleable Cast Iron	プラグ	SS400 or FCMB310	1
8 O Ring	NBR	Oリング	NBR	1
7 Bolts	Rolled Steel	ボルト	SS400	1set
4 Screen	Stainless Steel	スクリーン	SUS304	1
2 Cover	Ductile Cast Iron	ふた	FCD450	1
1 Body	Ductile Cast Iron	本体	FCD450	1
No. Name of Parts	Material	部品名	材質	Q.TY

TYPE SU-50 STRAINER ストレーナ

Approval	M. KUME
Check	Y. AOYAMA
Drawing	K. YASUDA
Drawing No.	Y-0987-2105
Date	9 MAR.2009

Specification	
Fluid	
Press.	MPa
Temp.	℃
Flow Rate	
Inside Screen	Mesh
Outside Screen	ø - Holes/cm ²

