

Specification	
Fluid	
Press.	MPa
Temp.	℃
Flow Rate	
Inside Screen	Mesh
Outside Screen	Ø - P

15	Plug	Carbon Steel	プラグ	SWCH	1
13	Plug	Carbon Steel	プラグ	SWCH	2
9	Thumb Screw	Alloyed Steel & Delrin500	サムスクリュー	SCM435 & デルリン500	2
8	O Ring	NBR	リング	NBR	1
7	O Ring	NBR	リング	NBR	1
6	Handle	Ductile Cast Iron	取手	FCD450	2
5	Screen	Stainless Steel & Cast Stainless Steel	スクリーン	SUS304 & SCS13	1
4	Cover Plate	Rolled Steel	リング止め板	SS400	1
3	Stopper Ring	Ductile Cast Iron	ストッパーリング	FCD450	1
2	Cover	Ductile Cast Iron	ふた	FCD450	1
1	Body	Ductile Cast Iron	本体	FCD450	1
No.	Name of Parts	Material	部品名	材質	Q. TY

TYPE ST-10 STRAINER
ストレーナ

Approval	H. Iwamoto
Check	M. Yoshida
Drawing	H. Okumura
Drawing No.	Y-1138-2105-1B
Date	22 NOV. 2012

(mm)

Size	L	H ₁	H ₂	E	Screen		d	Flange JIS 10K FF				⑬ Plug	⑮ Plug	Weight (kg)
					ds	ls		D	C	t	n-h			
125A	335	132	180	194	133	154.5	125	250	210	20	8-23	R 1/2	R 3/8	42



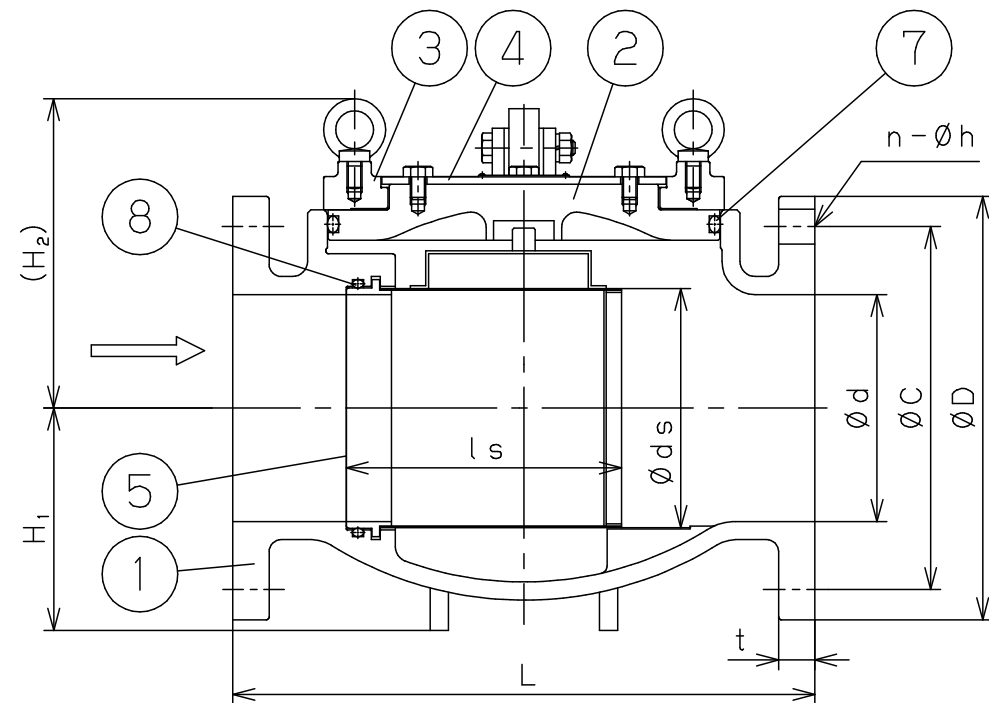
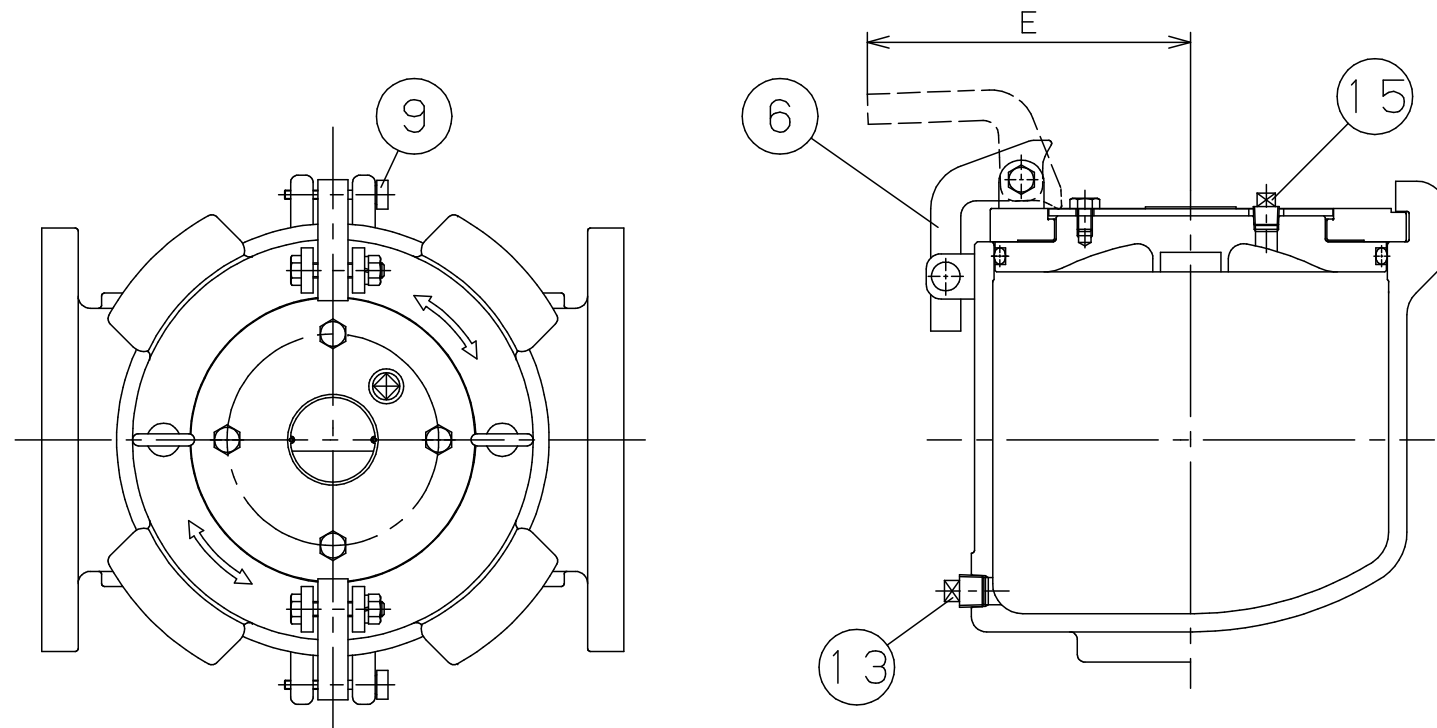

Specification	
Fluid	
Press.	MPa
Temp.	°C
Flow Rate	
Inside Screen	Mesh
Outside Screen	Ø - P

15	Plug	Carbon Steel	プラグ	SWCH	1
13	Plug	Carbon Steel	プラグ	SWCH	2
9	Thumb Screw	Alloyed Steel & Delrin500	サムスクリュー	SCM435 & デルリン500	2
8	O Ring	NBR	リング	NBR	1
7	O Ring	NBR	リング	NBR	1
6	Handle	Ductile Cast Iron	取手	FCD450	2
5	Screen	Stainless Steel & Cast Stainless Steel	スクリーン	SUS304 & SCS13	1
4	Cover Plate	Rolled Steel	リング止め板	SS400	1
3	Stopper Ring	Ductile Cast Iron	ストッパーリング	FCD450	1
2	Cover	Ductile Cast Iron	ふた	FCD450	1
1	Body	Ductile Cast Iron	本体	FCD450	1
No.	Name of Parts	Material	部品名	材質	Q. TY

TYPE ST-10 STRAINER
ストレーナ

Approval	H. Iwamoto
Check	M. Yoshida
Drawing	H. Okumura
Drawing No.	Y-1138-2105-2B
Date	22 NOV. 2012

(mm)

Size	L	H ₁	H ₂	E	Screen		d	Flange JIS 10K FF				⑬ Plug	⑮ Plug	Weight (kg)
					ds	ls		D	C	t	n-h			
150A	385	147	205	214	158	182	150	280	240	22	8-23	R 1/2	R 3/8	60
200A	470	175	240	249	208	228	200	330	290	22	12-23	R 1/2	R 3/8	100



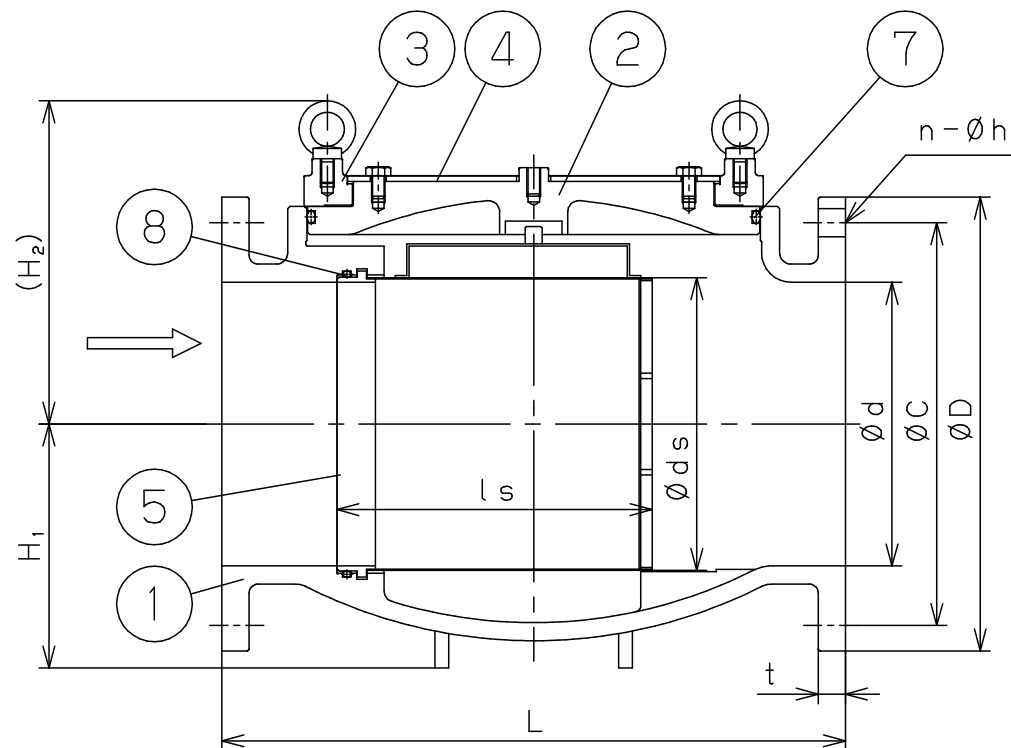
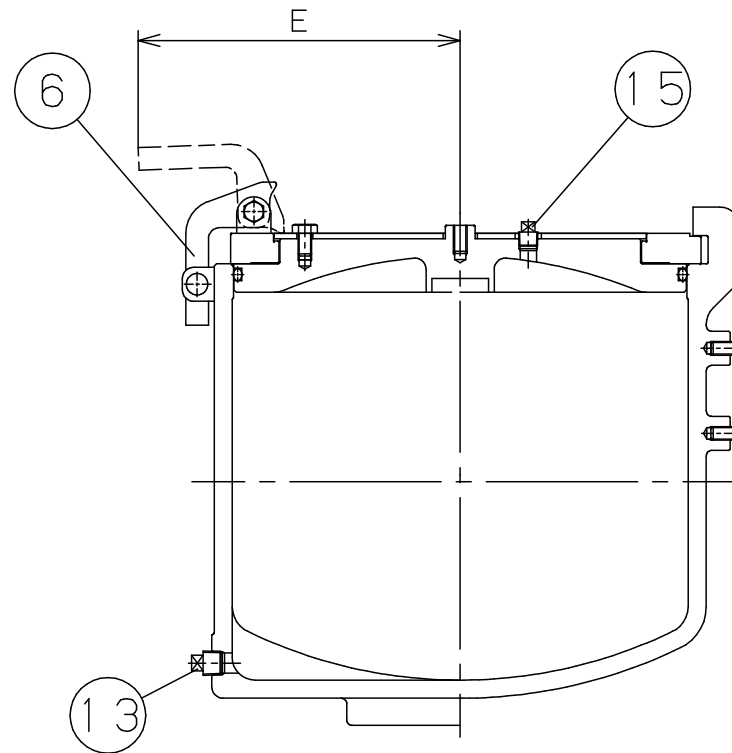
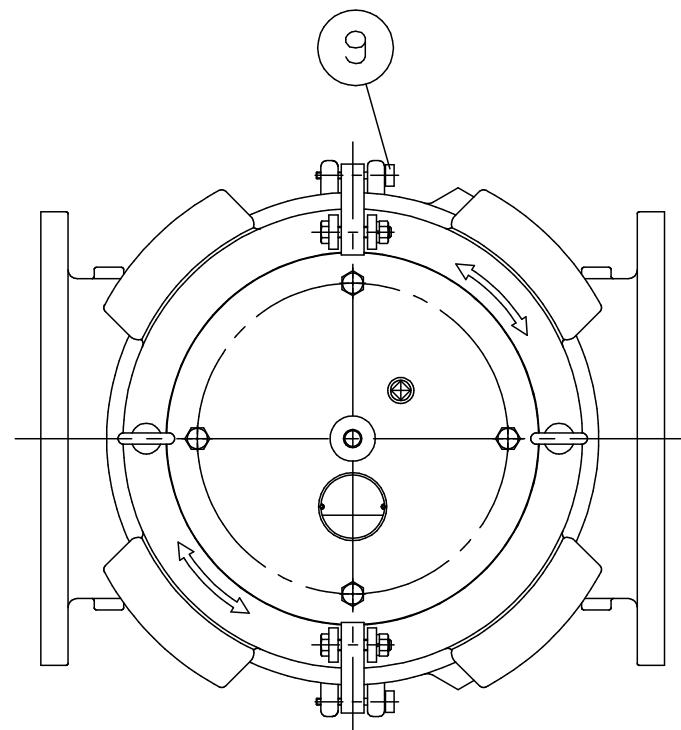

Specification			
Fluid			
Press.		MPa	
Temp.		℃	
Flow Rate			
Inside Screen		Mesh	
Outside Screen	∅	-	P

15	Plug	Carbon Steel	プラグ	SWCH	1
13	Plug	Carbon Steel	プラグ	SWCH	2
9	Thumb Screw	Alloyed Steel & Delrin500	サムスクリュー	SCM435 & デルリン500	2
8	O Ring	NBR	リング	NBR	1
7	O Ring	NBR	リング	NBR	1
6	Handle	Ductile Cast Iron	取手	FCD450	2
5	Screen	Stainless Steel & Cast Stainless Steel	スクリーン	SUS304 & SCS13	1
4	Cover Plate	Rolled Steel	リング止め板	SS400	1
3	Stopper Ring	Ductile Cast Iron	ストッパーリング	FCD450	1
2	Cover	Ductile Cast Iron	ふた	FCD450	1
1	Body	Ductile Cast Iron	本体	FCD450	1
No.	Name of Parts	Material	部品名	材質	Q. TY

TYPE ST-10 STRAINER
ストレーナ

Approval	H. Iwamoto
Check	M. Yoshida
Drawing	H. Okumura
Drawing No.	Y-1138-2105-3B
Date	22 NOV. 2012



(mm)

Size	L	H ₁	H ₂	E	Screen		d	Flange JIS 10K FF				⓫ Plug	⓬ Plug	Weight (kg)
					ds	ls		D	C	t	n-h			
250A	550	215	285	285	258	278	250	400	355	24	12-25	R 1/2	R 3/8	156